

ESCALA 1:2

DEFLEXION MAX. L/175

Los límites de fabricación para los perfiles serán los que se encuentren debajo de las curvas graficadas.

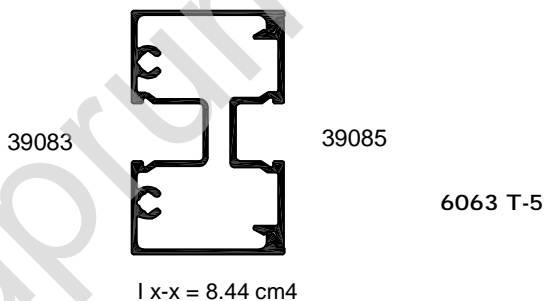
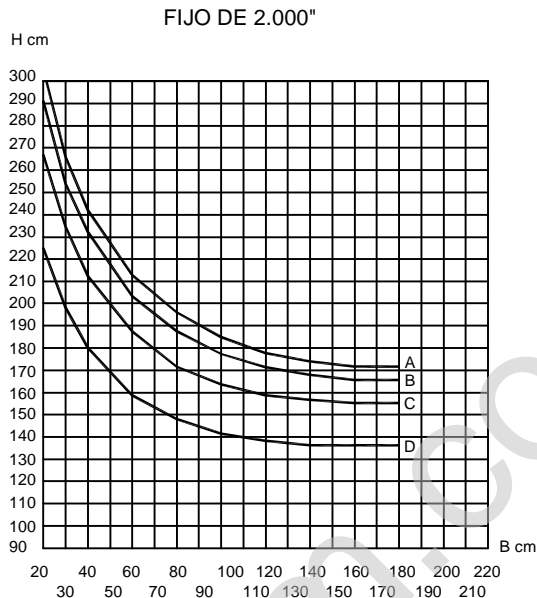

Valores de presión por velocidad de viento

Curvas	Presión del diseño	Velocidad de viento	Zona
A	45 Kg/m ²	80 Km/h	Centro de grandes ciudades
B	50 Kg/m ²	100 Km/h	Barrios Residenciales
C	65 Kg/m ²	120 Km/h	Campo Abierto
D	110 Kg/m ²	160 Km/h	Zona Costera

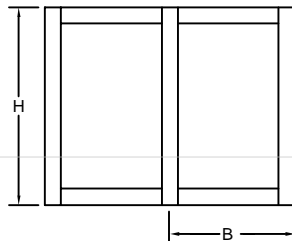

Los límites de un cancel van en función de la combinación de resistencia del perfil de aluminio, el cristal y los accesorios que lo integran.

Verificar que la deflexion del perfil sea compatible con el vidrio utilizado

ALUMINIO

CLAVE	PZAS POR ATADO	LARGO STD.
7792	16	6.10
9086	8	6.10
24051	16	6.10
28586	4	6.10
28591	8	6.10
69083	10	6.10
39083	10	6.10
39084	10	6.10
69085	18	6.10
39085	18	6.10
39088	32	6.10

www.cuprum.com.mx